

OWNERS MANUAL

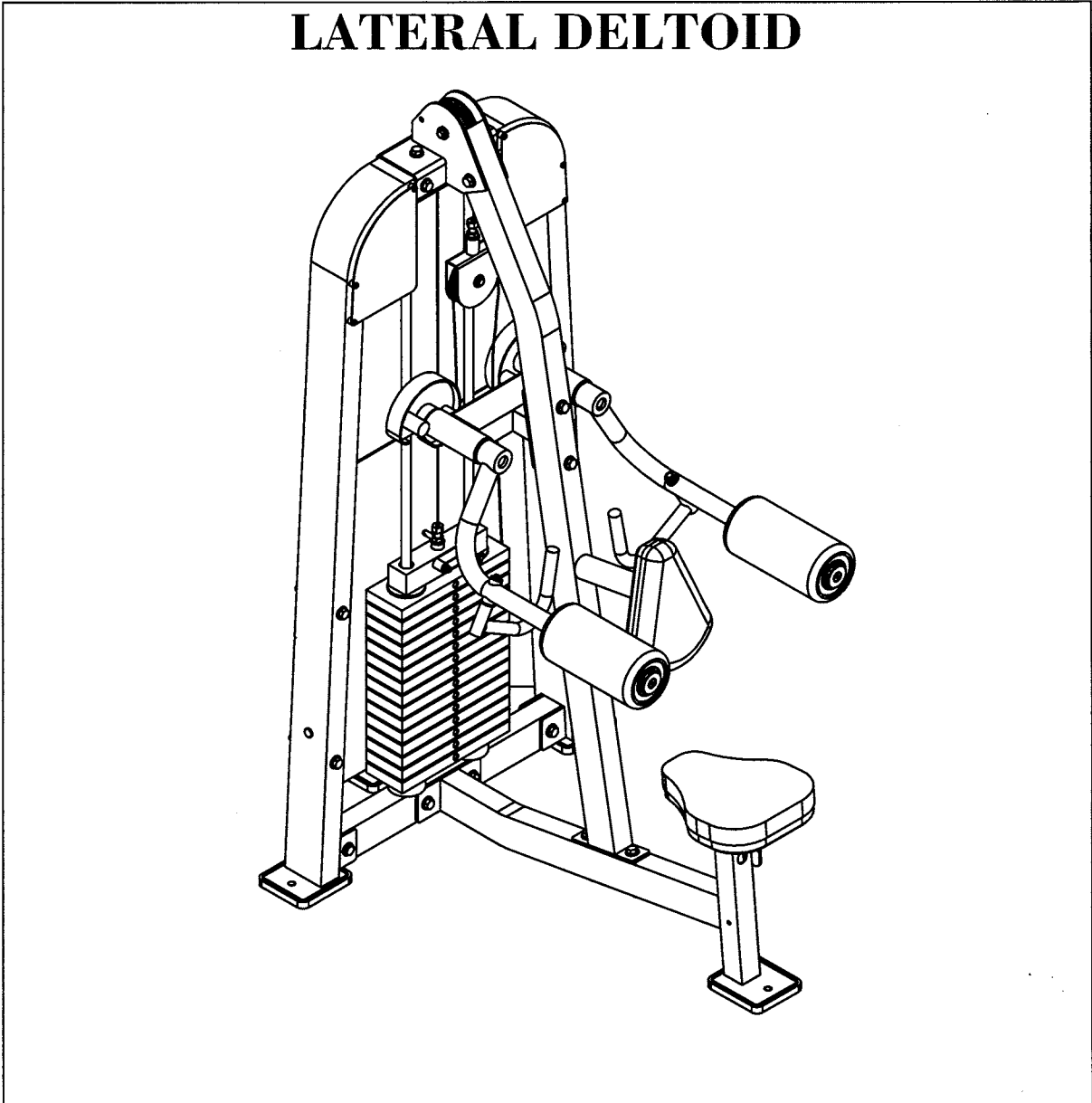

HS1525 LATERAL DELTOID



Note: Both Serial Number and Model Number are Required when Ordering Parts

RECORD SERIAL NUMBER HERE

Customer Service

(800) 548-5438

(858) 578-7676

Fax

(858) 578-9558

FEBRUARY 2003

OWNERS MANUAL

CONTENT

INSTRUCTIONS (Step 1).....	2
FRAME ASSEMBLY (Step 2).....	4
CABLE ASSEMBLY (Step 3).....	17
PRE-ASSEMBLED PARTS	23
PART LISTING	25
HARDWARE LISTING.....	26
BOLT SIZING CHART.....	27
WASHER SIZING CHART.....	29
WEIGHT CHART.....	31
DECAL PLACEMENT.....	33
WEIGHT TRAINING TIPS	39
WEIGHT TRAINING EXERCISE LOG.....	40
MAINTENANCE SCHEDULE.....	41
GENERAL MAINTENANCE INFORMATRION.....	42
LIMITIED WARRANTY.....	44

OWNERS MANUAL

Step 1 INSTRUCTIONS

Before beginning assembly please take the time to read the instructions thoroughly. Please use the various lists in this manual to make sure that all parts have been included in your shipment. When ordering, use the part number and description from the lists. Use only Hoist replacement parts when servicing. Failure to do so will void your warranty and could result in personal injury.

Hoist equipment is designed to provide the smoothest, most effective exercise motion possible. After assembly, you should check all functions to ensure correct operation. If you experience problems, first recheck the assembly instructions to locate any possible errors made during assembly. If you are unable to correct the problem, call your authorized Hoist dealer. Be sure to have your serial number and this manual when calling. When all parts have been accounted for, continue on.

TOOLS REQUIRED

Socket Wrench

1/2", 9/16" and 3/4" Sockets

3/4" Open end Wrench

Crescent Wrench

Rubber mallet

Tape Measure

OWNERS MANUAL

OWNERS MANUAL

Step 2 FRAME ASSEMBLY

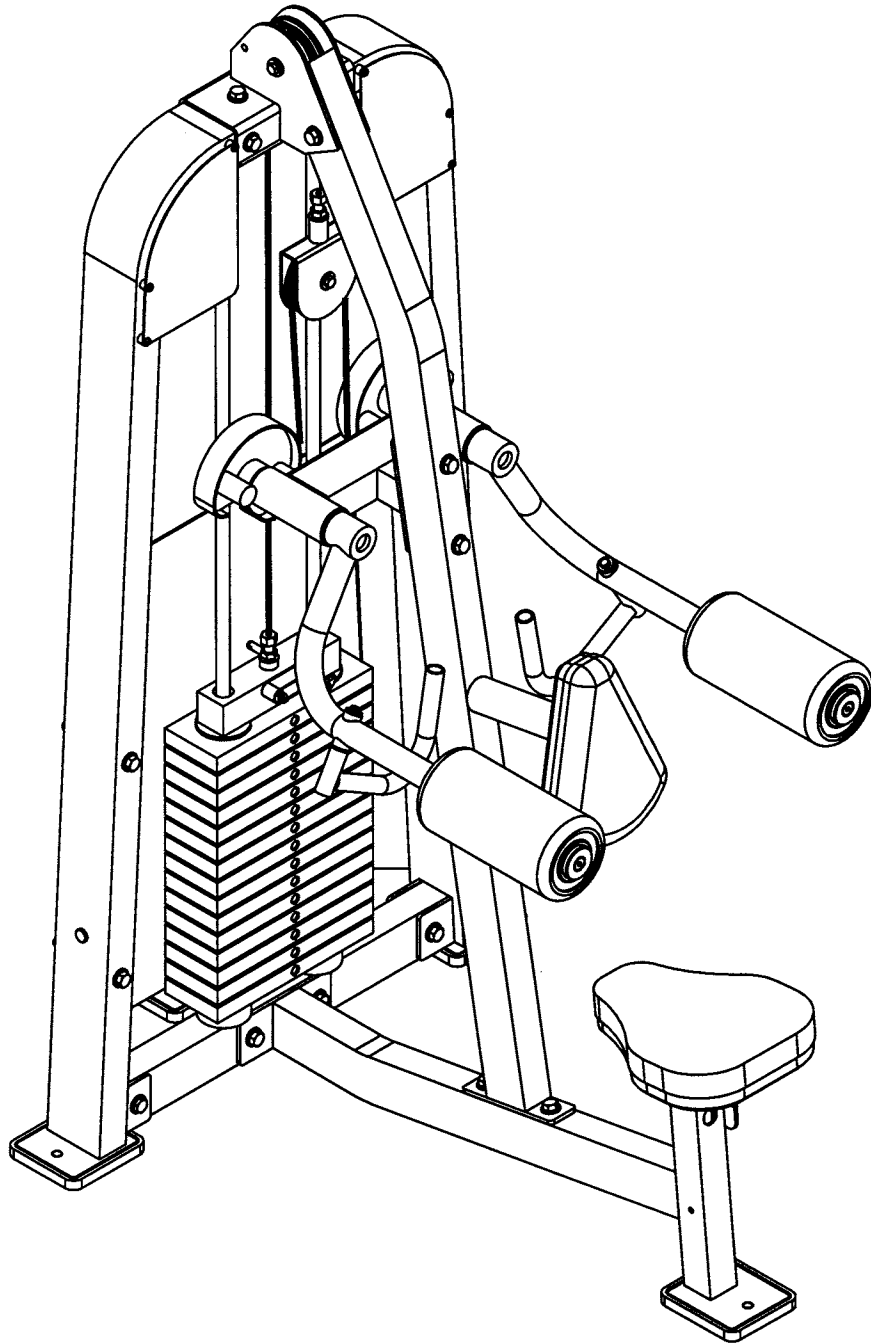

OWNERS MANUAL

Step 2a FRAME ASSEMBLY

Start assembly by attaching both (1)'s to (4). Attach (3) to both (1)'s. Then attach (2) and (101) to (4). Hand Tighten bolts. Bolts will be Wrench Tighten later in assembly.

Part Descriptions

- 1 - Weight Frame Upright
- 2 - Rear Support Tie
- 3 - Top Pulley Mount
- 4 - Weight Stack Mount
- 101 - Seat Support

Hardware Descriptions

- A - 1/2"-13UNC x 4 3/4" Hex Head Bolt (WZ)
- B - 1/2"-13UNC x 3" Hex Head Bolt (WZ)
- AA - 1/2" Flat Washer
- BA - 1/2" Thin Nylok Nut
- CA - Rubber Foot Pad

OWNERS MANUAL

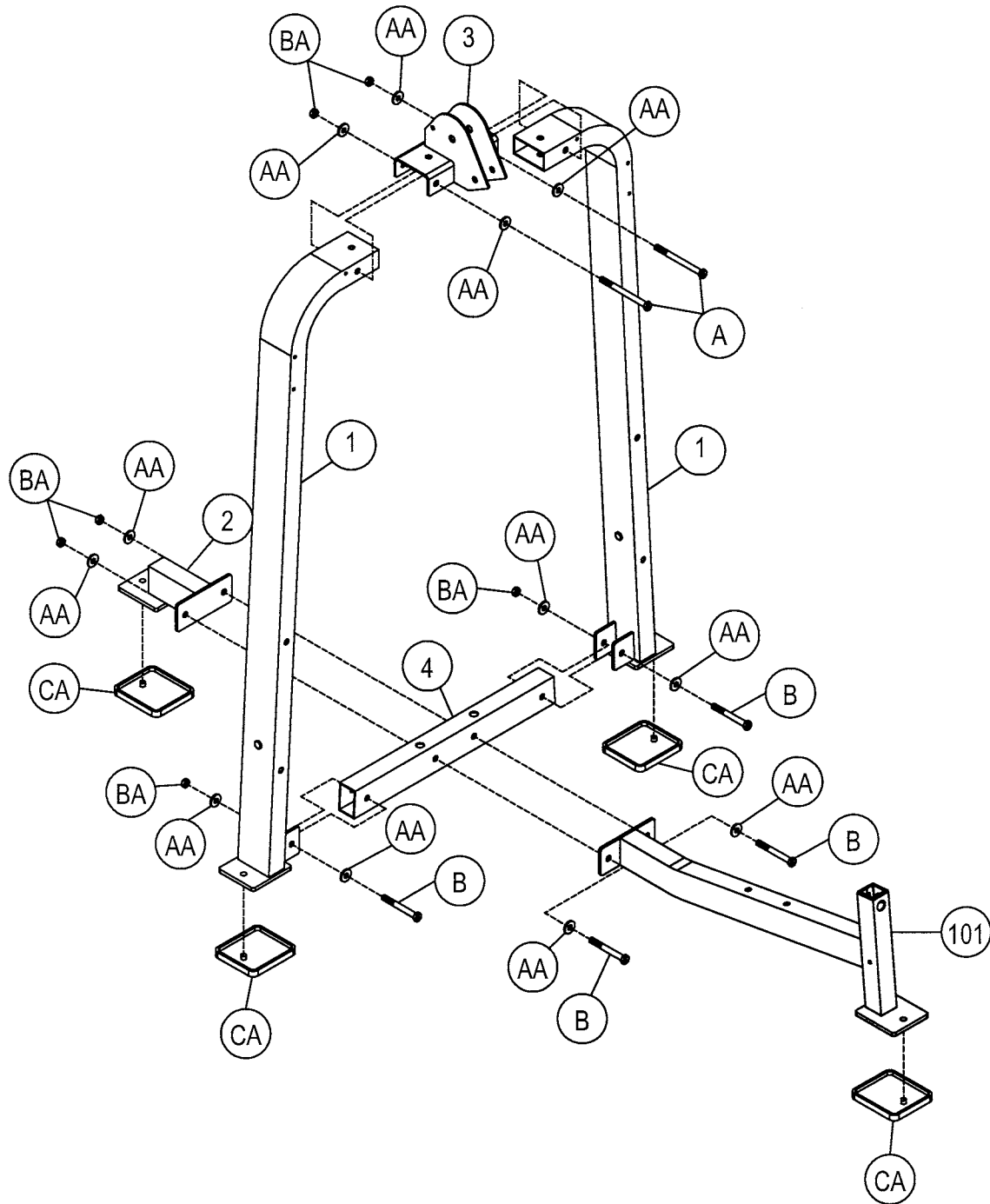

OWNERS MANUAL

Step 2b

FRAME ASSEMBLY

Continue assembly by sliding (6) through (CC) and slide them both into (4). Tilt both (6)'s forward enough to allow room to slide the Weight Plates on. Slide all 15 (8)'s onto both (6)'s. Now slide (7) onto both (6)'s. Next slide (5) over both (6)'s. Angle both (6)'s vertical and secure (5) to both (1) and (3). Wrench Tighten all bolts on the machine at this point.

Part Descriptions

- 1 - Weight Frame Upright
- 3 - Top Pulley Mount
- 4 - Weight Stack Mount
- 5 - Guide Rod Top Mount
- 6 - Guide Rod
- 7 - Top Weight
- 8 - 12 1/2 lb Intermediate Plate

Hardware Descriptions

- C - 1/2"-13UNC x 3 1/4" Hex Head Bolt (WZ)
- V - 5/16"-18UNC x 5/16" Socket Set Screw (WZ)
- AA - 1/2" Flat Washer
- BA - 1/2" Thin Nylok Nut
- CC - Weight Stack Bumper

OWNERS MANUAL

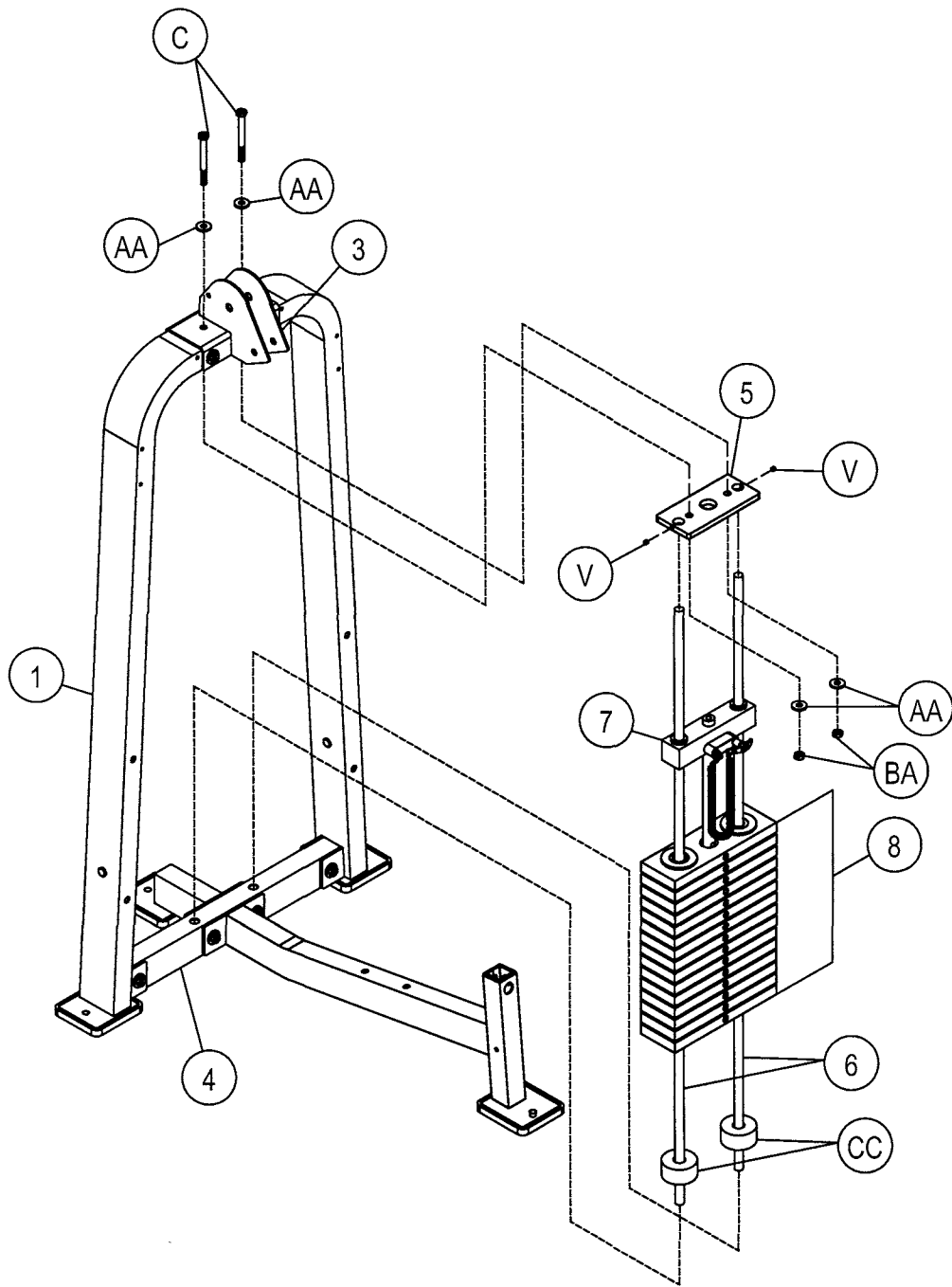

OWNERS MANUAL

Step 2c FRAME ASSEMBLY

Continue assembly by attaching the top of (103) to (3) and the bottom of (103) to (101). Now attach (102) to the backside of (103). Wrench Tighten bolts.

Part Descriptions

3 - Top Pulley Mount
101 - Seat Support
102 - Arm Housing
103 - Shoulder Upright

Hardware Descriptions

B - 1/2"-13UNC x 3" Hex Head Bolt (WZ)
D - 1/2"-13UNC x 3 3/4" Hex Head Bolt (WZ)
AA - 1/2" Flat Washer
BA - 1/2" Thin Nylok Nut

OWNERS MANUAL

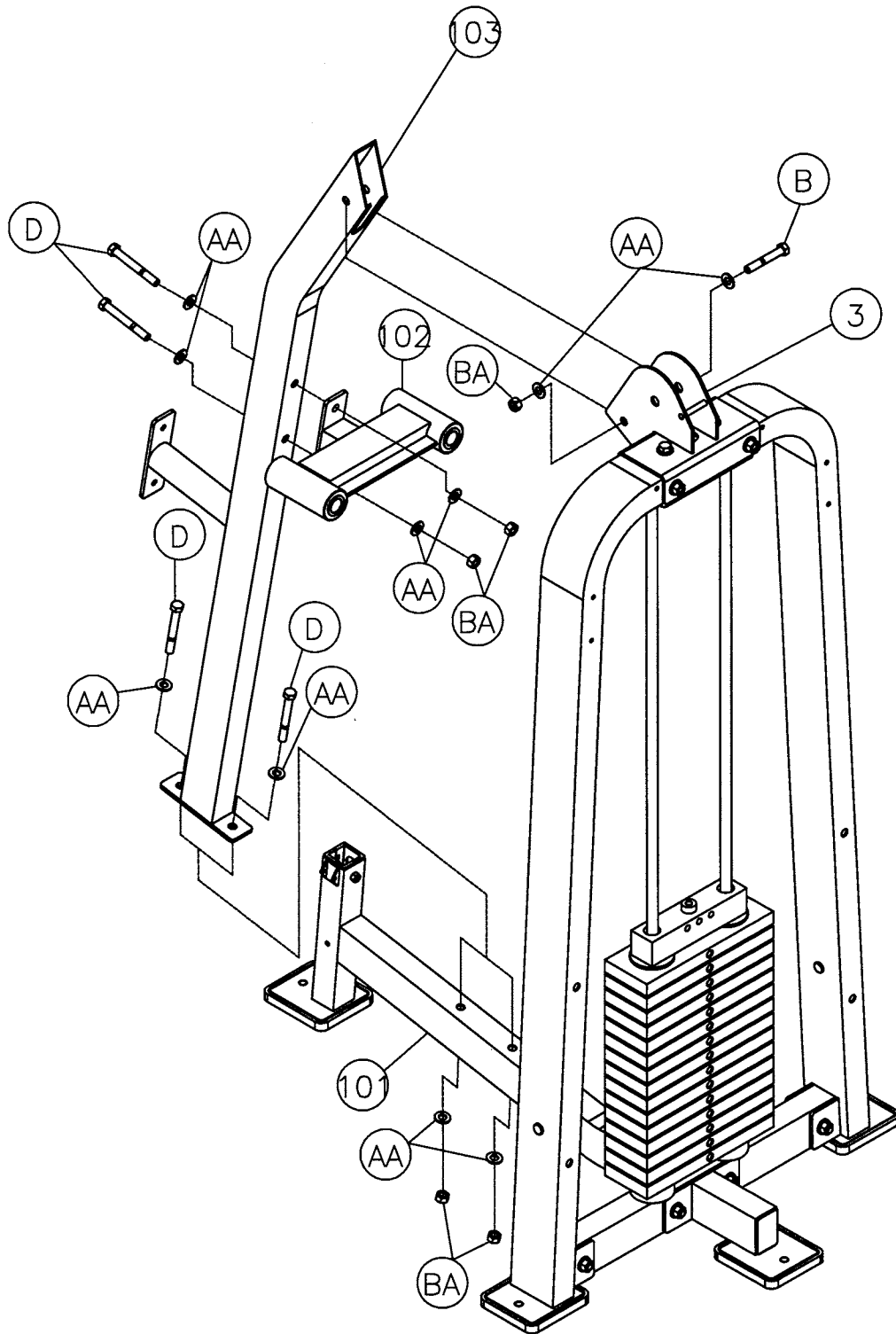

OWNERS MANUAL

Step 2d

FRAME ASSEMBLY

Continue assembly by attaching two(CD)'s to (105). Slide (107)'s through (102). Place (CF) in the grove on (107), then slide (105) onto (107) insurring (CF) is lined up and slides through the key slot on (105) (See detail 1 on page 12). Secure with aluminum bolt on cap (CE). Repeat assembly process for other arm assembly using (104) instead of (105). Take (106) and insert it through (107) and fasten it with (DN).

Part Descriptions

102 - Arm Housing
104 - Cable Guide (Left)
105 - Cable Guide (Right)
106 - Handle
107 - Arm Assmebly

Hardware Descriptions

E - 1/2"-13UNC x 1" Button Head Bolt (WZ)
AA - 1/2" Flat Washer
AB - 1/2" Internal Tooth Lock Washer
AG - 1/2" Thrust Washer
BA - 1/2" Thin Nylok Nut
CD - Plastic Stopper
CE - Alumamun Bolt on Cap
CF - Square Key Stock
DN - Retaining Clip

OWNERS MANUAL

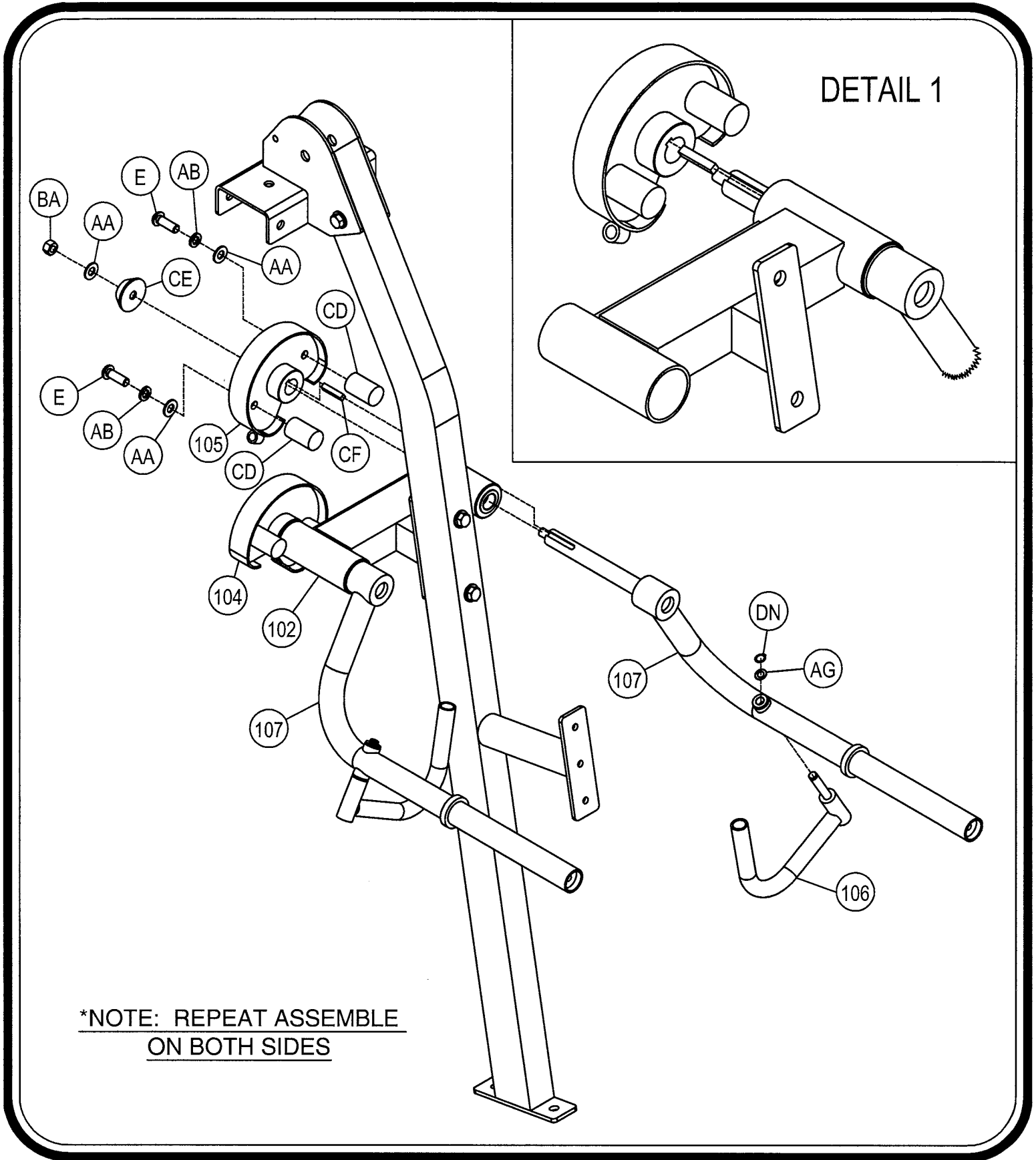

*NOTE: REPEAT ASSEMBLE
ON BOTH SIDES

OWNERS MANUAL

Step 2e UPHOLSTERY ASSEMBLY

Continue assembly by attaching (108) to (103). Next attach (9) to (10), then attach (11) to (101). Slide (10) into (101).

Part Descriptions

- 9 - Seat Pad Upholstery Assembly
- 10 - Seat Assembly
- 11 - Seat Latch Assembly
- 101 - Seat Support
- 103 - Shoulder Upright
- 108 - Chest Pad Upholstry Assembly

Hardware Descriptions

- F - 5/16"-18UNC x 1 1/4" HHB (WZ)\
- G - Square Head Set Screw
- AC - 5/16" Flat Washer
- AD - 5/16" Internal Tooth Flat Washer
- CG - Seat Adjuster Pin
- CH - Latch Spring
- CJ - Seat Adjuster C-Clip

OWNERS MANUAL

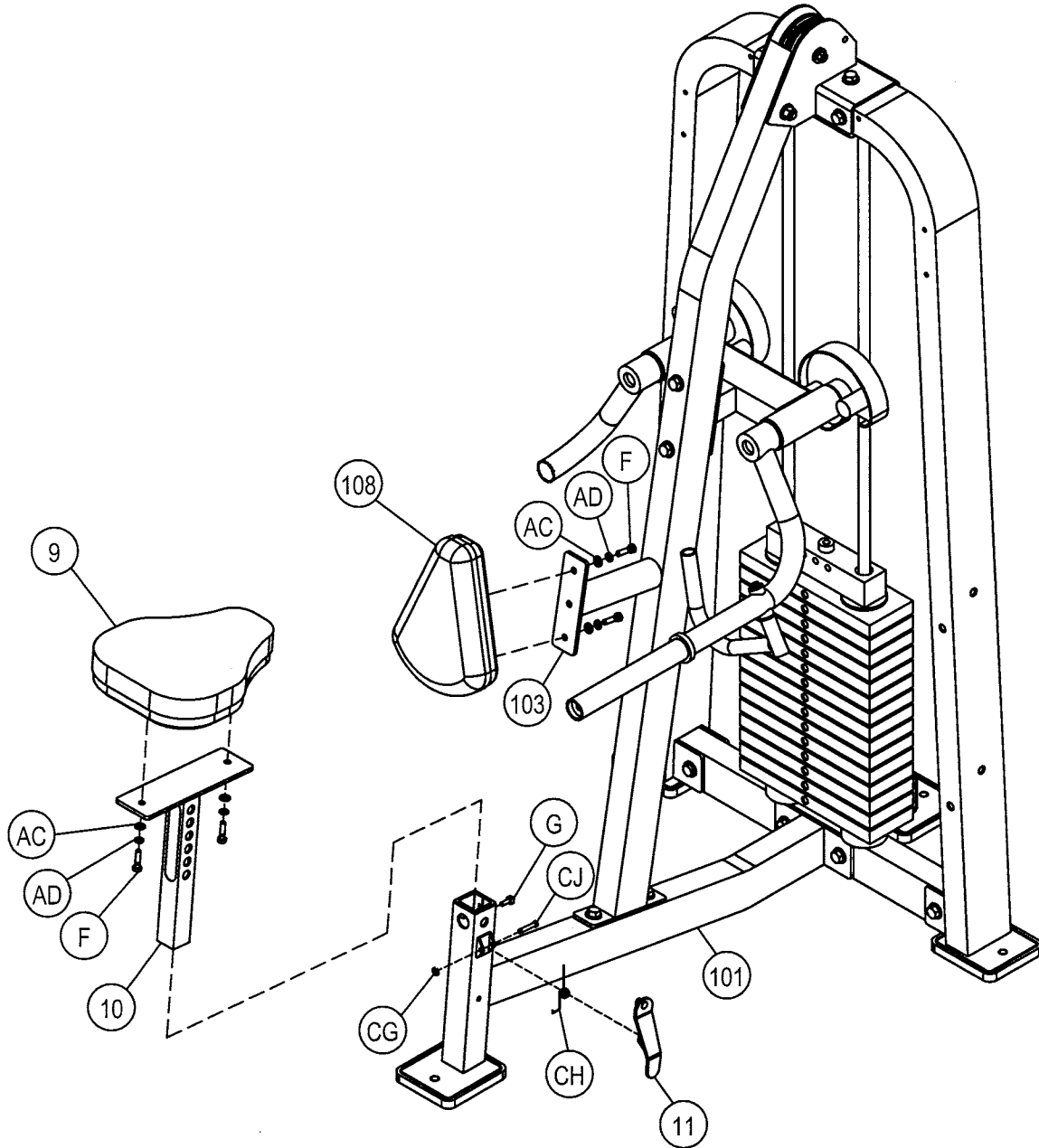

OWNERS MANUAL

Step 2f PULLEY ASSEMBLY

The following page shows each pulleys location and the hardware used to install it. When installing each puley, refer to the **Cable** Insallation diagram on page 18 and 20 to insure the **cab**le is routed properly around each pulley and is on the correct side of **cab**le guard pins bolts. Attach the upholstery (109) as shown. Wrench Tighten all bolts.

Part Descriptions

3 - Top Pulley Mount
12 - Floating Pulley Mount
107 - Arm Assmebly
109 - Arm Pad Upholstery

Hardware Descriptions

H - 3/8"-16UNC x 3" HHB (WZ)
J - 3/8"-16UNC x 1 3/4" HHB (WZ)
K - 3/8"-16UNC x 1" FHS (WZ)
AE - 3/8" Flat Washer
BB - 3/8" Thin Nylok Nut
CK - 4 1/2" Pulley Wheel
CL - 11/16" Flanged Spacer
CM - Aluminum Cap (Flat Head)
CN - Plastic Flanged Bushing

OWNERS MANUAL

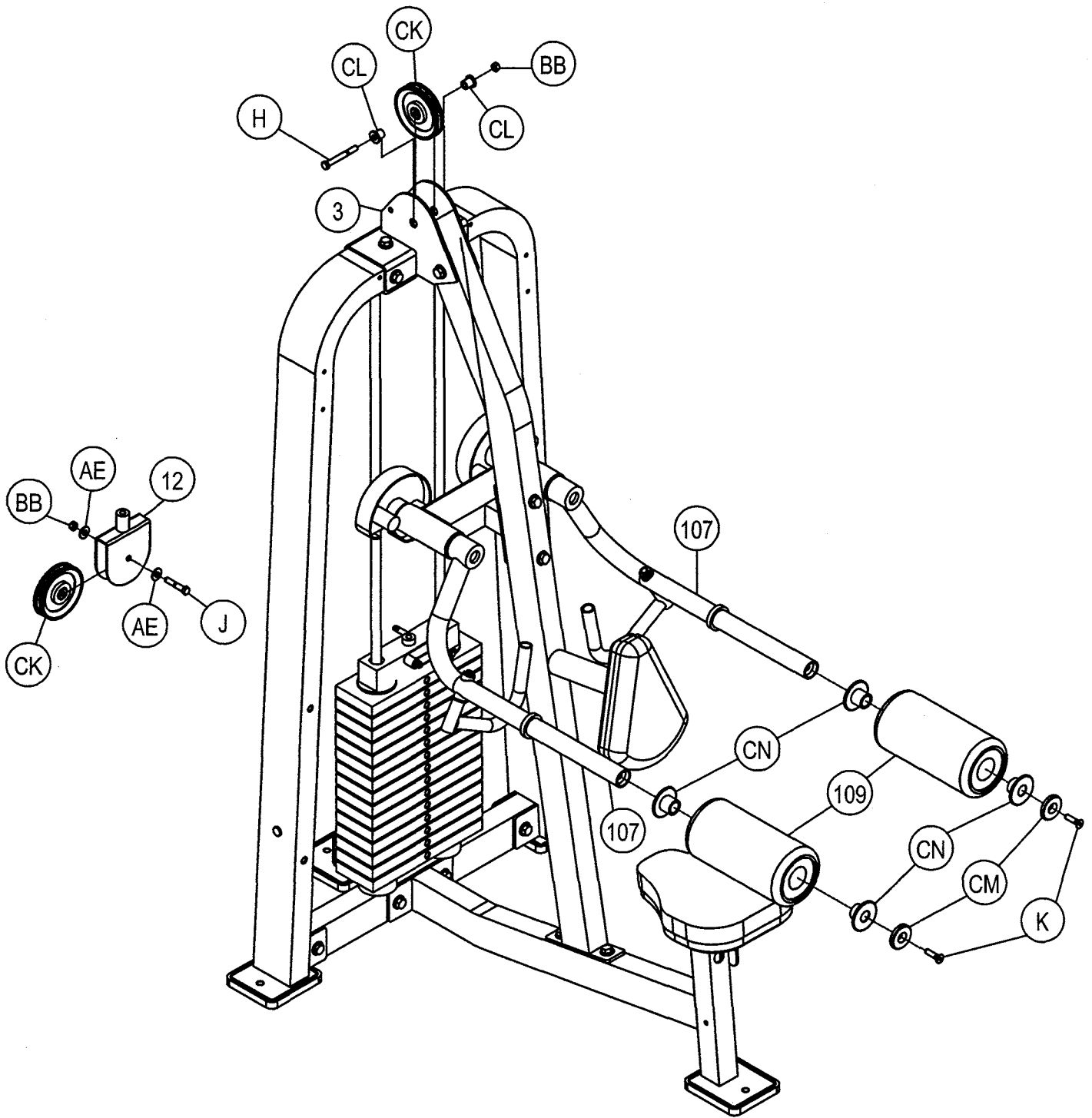

OWNERS MANUAL

Step 3

CABLE INSTALLATION

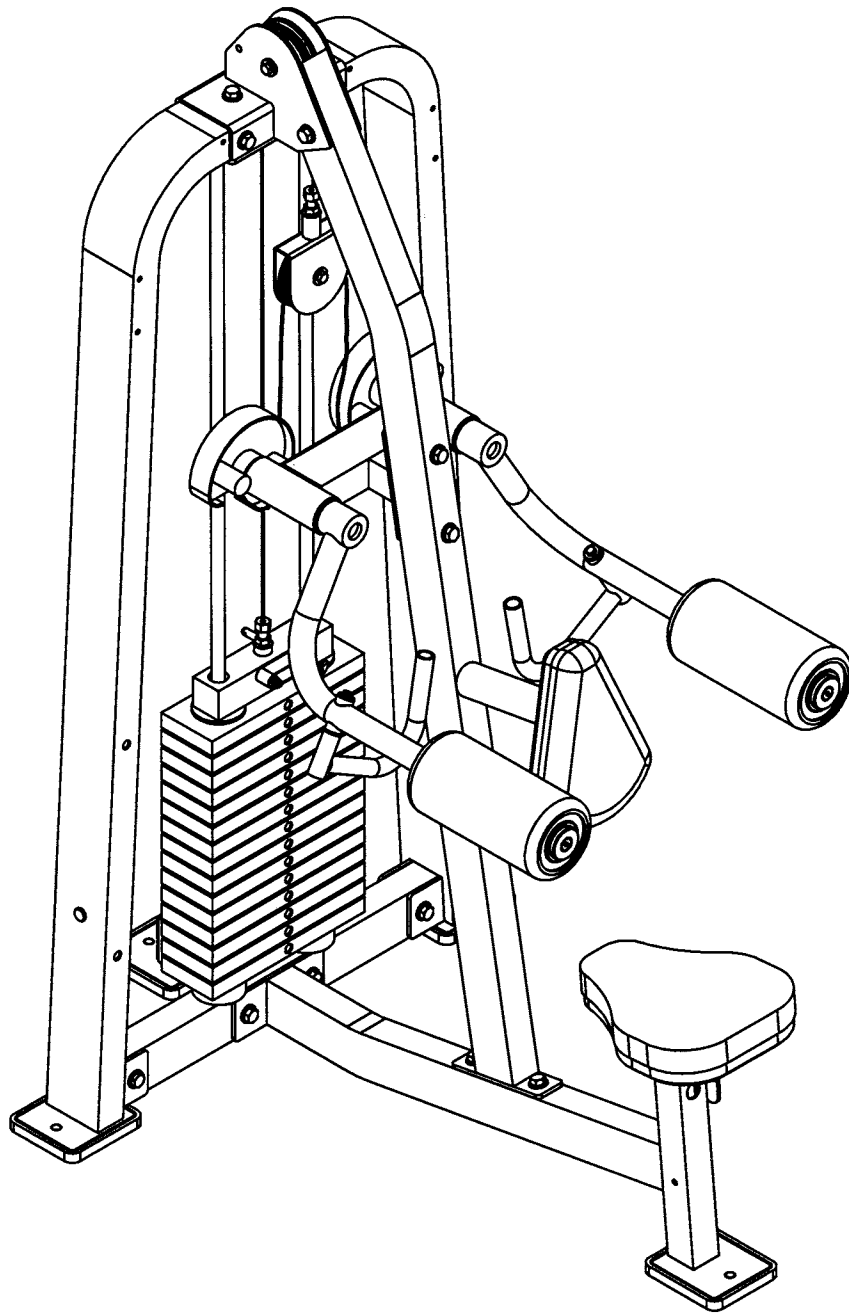

OWNERS MANUAL

Step 3a

CABLE #1 ASSEMBLY

NOTE:
BE SURE THAT THE **CABLE**
RUNS BETWEEN THE PULLEY
AND THE GUARD PIN.

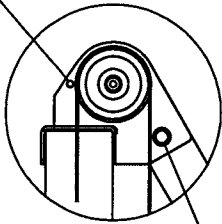

NOTE:
BE SURE **CABLE** RUNS
UNDER TOP SIDE
OF FRAME BOLT.



FINE TUNING:
LOOSEN JAM NUT AND
THREAD BOLT IN/OUT TO GIVE
THE **CABLE** PROPER
TENSION. RE-TIGHTEN
JAM NUT.

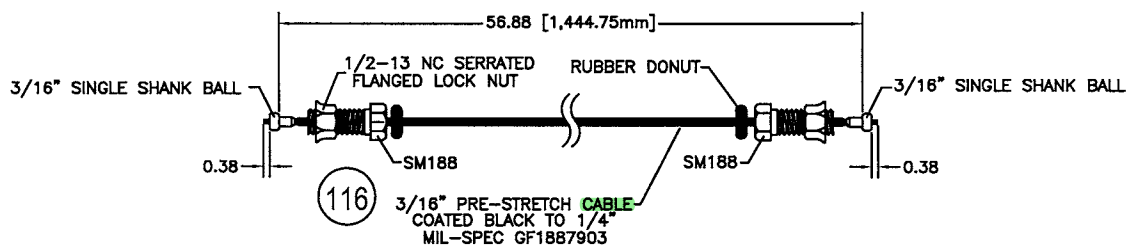
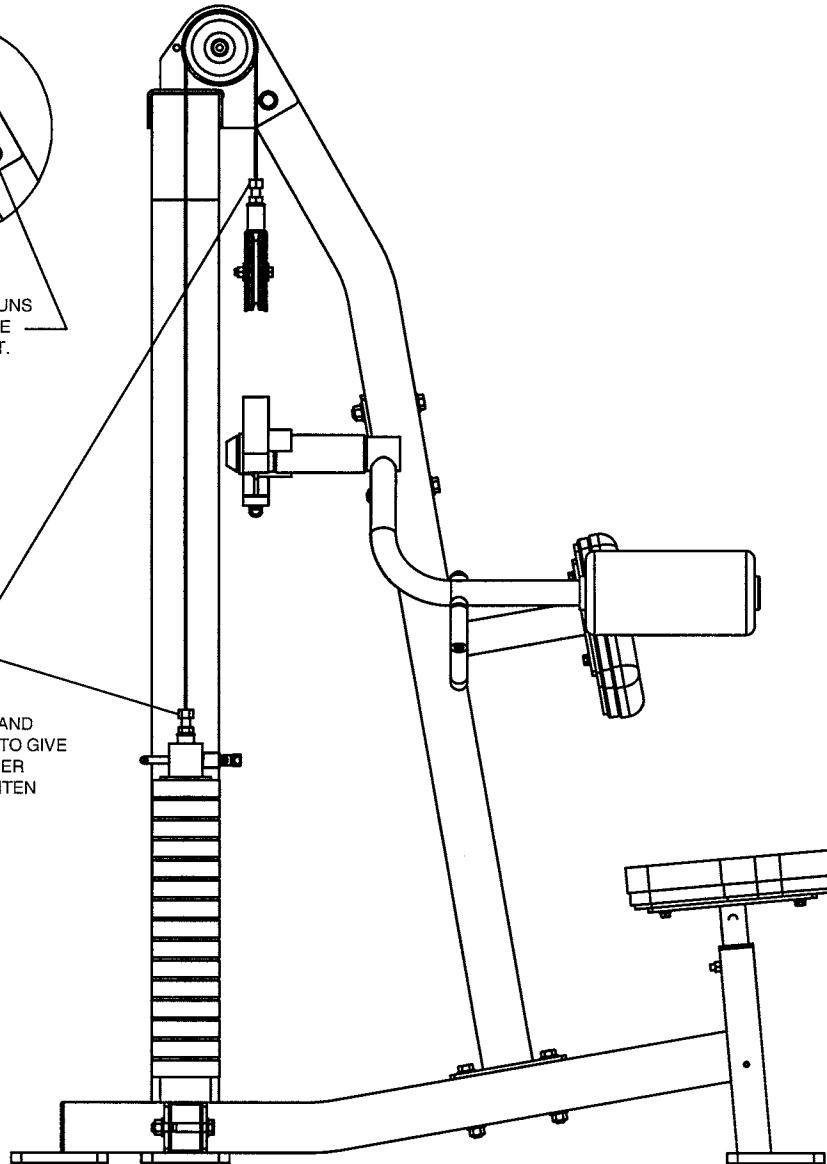

OWNERS MANUAL

OWNERS MANUAL

Step 3b

CABLE #2 ASSEMBLY

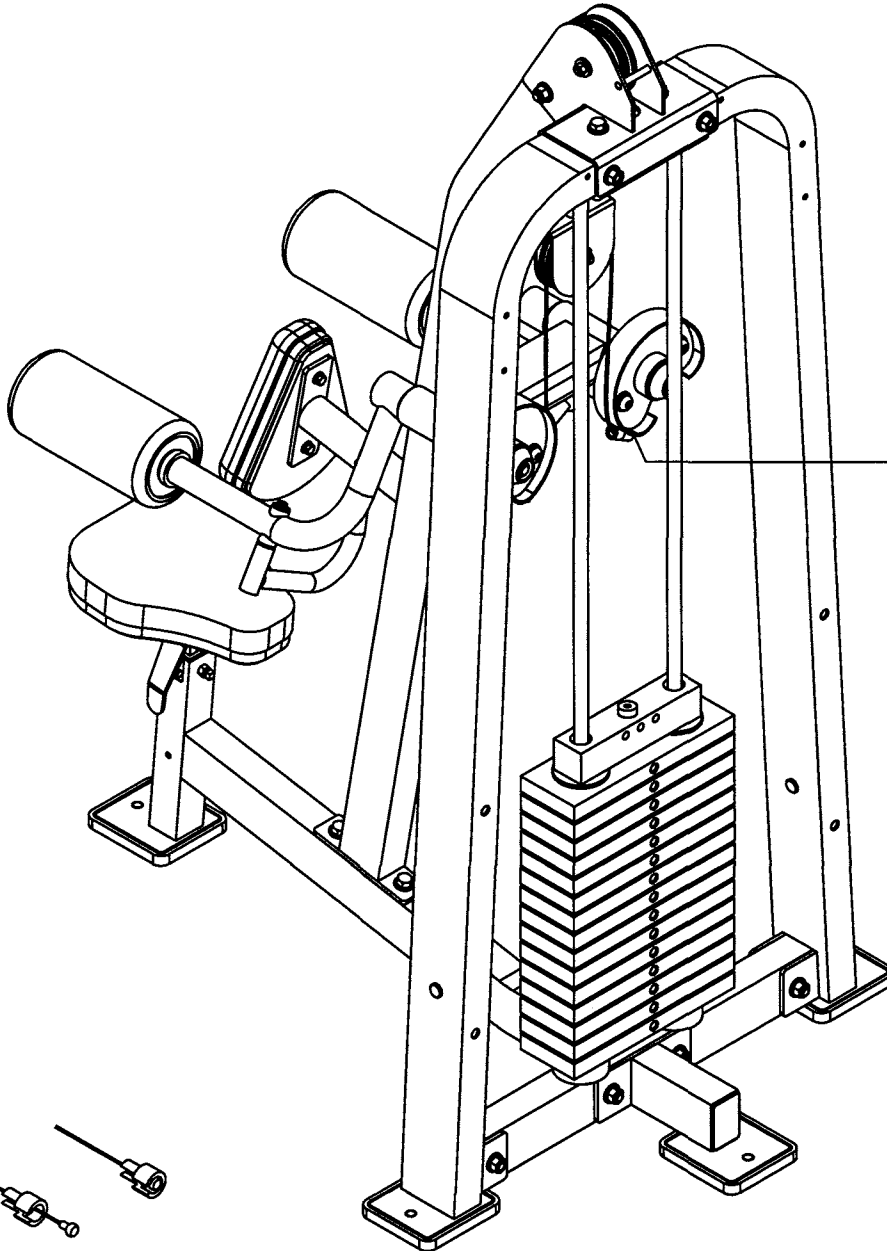

NOTE:
REFERENCE THE QUICK RELEASE CABLE
LOCK ASSEMBLY FOR INSTALLATION.

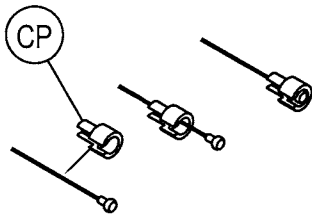

QUICK RELEASE **CABLE** LOCK ASSEMBLY

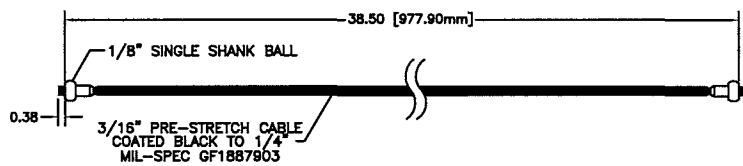

117

OWNERS MANUAL

Step 3c

CABLE INSTALLATION

Finish assembly by attaching (13) to both (1)'s. Then attach (CQ) to (1). Repeat assembly for (CR). Wrench Tighten bolts.

IMPORTANT

Now that the HS1525 machine is completely assembled take time to assure that you unit is assembled square and perpendicular. To check this use a Level to check that the Guide Rods are Perpendicular in both directions. If they are not perpendicular in both directions. it will be necessary to loosen some Frame hardware to re-align the Frame and re-tighten the bolts.

Part Descriptions

1 - Weight Frame Upright
13 - Weight Frame Shield

Hardware Descriptions

L - 1/2"-13UNC x 4 1/2" HHB (WZ)
M - 1/4"-20UNC x 5" BHB (WZ)
AA - 1/2" Flat Washer
AF - 1/4" Flat Washer
BA - 1/2" Thin Nylok Nut
BC - 1/4" Nylok Nut
CQ - HS1525 Placard (Right)
CR - HS1525 Placard (Left)
CS - .40 Lg. Spacer

OWNERS MANUAL

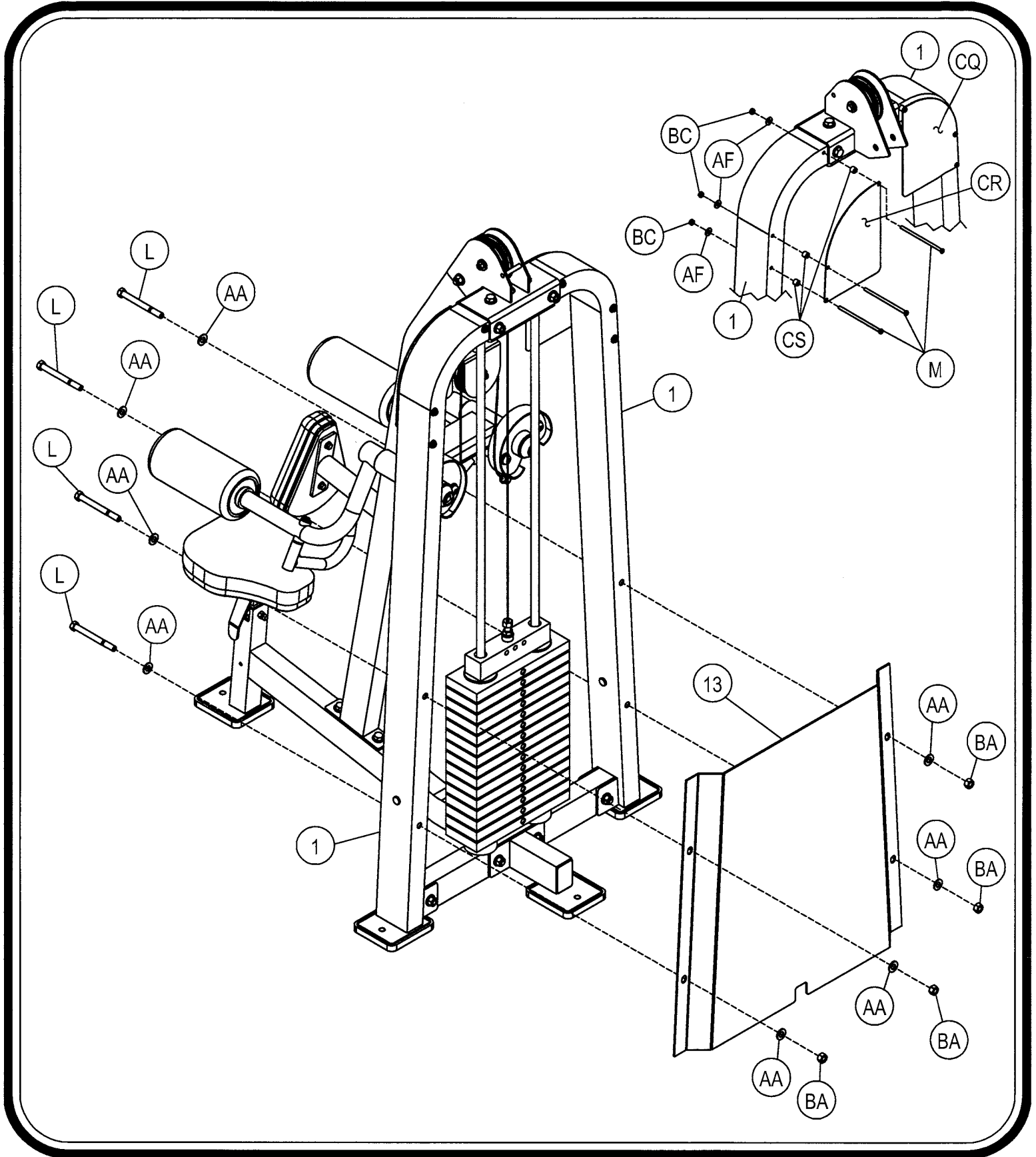

OWNERS MANUAL

PRE-ASSEMBLY PARTS

Part Descriptions

2 - Rear Tie
7 - Top Weight Plate
8 - 12 1/2 lb Weight Plate
10 - Seat Assembly
11 - Seat Latch Assembly
101 - Seat Support Assembly
102 - Arm Housing
106 - Handel
107 - Arm Assembly

Hardware Descriptions

CT - Ø 1" x 13" Closed End Foam Grip
CU - EZ Guide Sleeves
CV - 1 1/2" x 1 1/2" End Cap
CW - Bushing
CX - 1" Flanged Ball Bearing
CY - 1/2" Flanged Oilite
CZ - Lanyard Coil
DA - Selector Pin
DB - Lanyard/Selector Pin Stand Off
DC - 7/16" x 2 3/4" Lg. Roll Pins
DD - 16 Plate Selector Pin
DE - Guide Rod Bushing
DF - Rubber Thumb Latch
DK - 2" x 3" Flat End Cap
DM - Ø1" End Cap
DW - Plug

OWNERS MANUAL

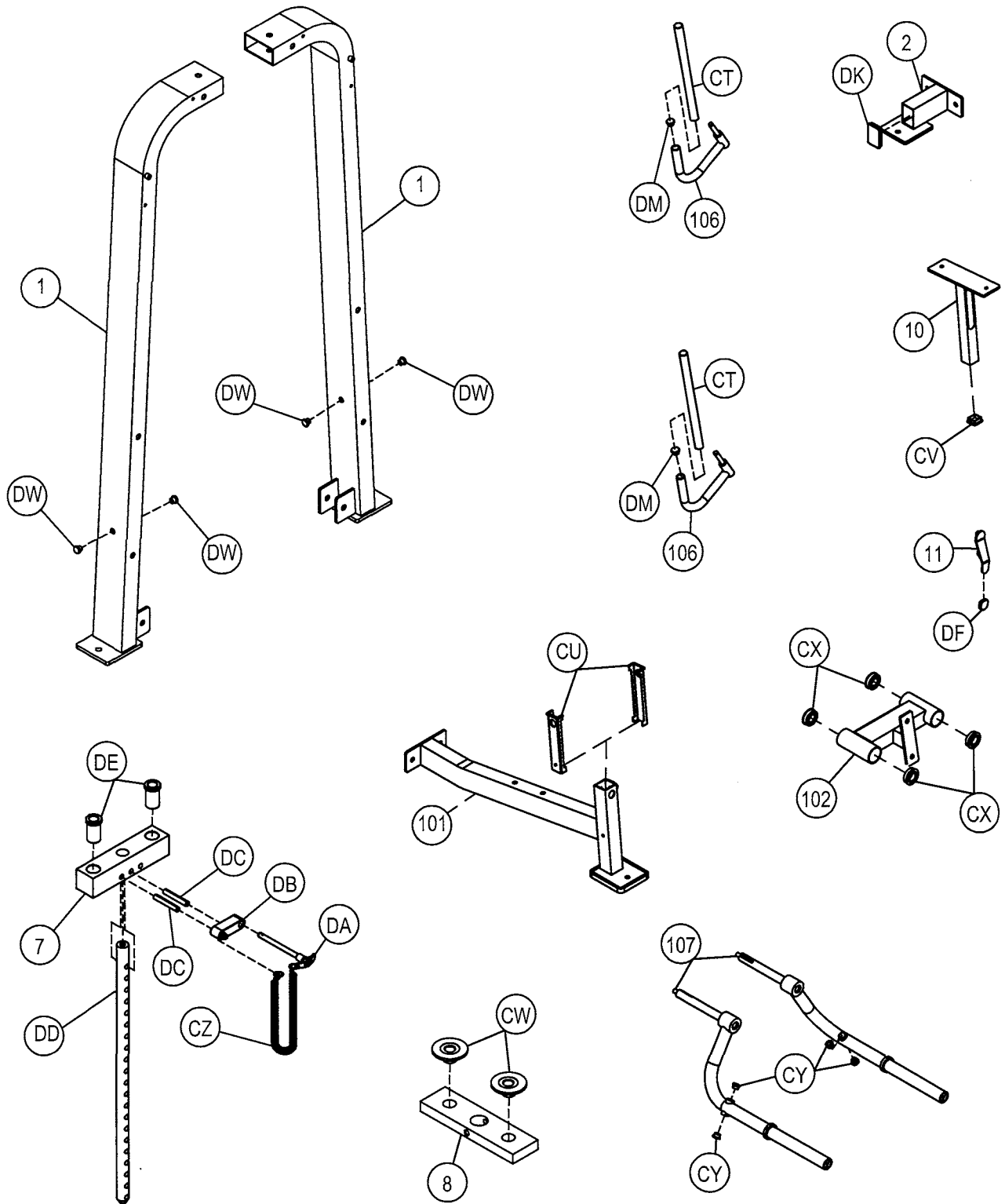

OWNERS MANUAL

PART LISTING

<u>Key#</u>	<u>Qty.</u>	<u>Part Number</u>	<u>Description</u>
1	2	026-01X0864	Weight Frame Upright
2	1	026-01X0817	Rear Support Tie
3	1	026-01X0859	Top Pulley Mount
4	1	026-01T0545	Weight Stack Support
5	1	026-01P0819	Guide Rod Top Mount
6	2	026-01G0159	Guide Rod
7	1	026-1300034	8 1/4 lb. Top Weight Plate
8	15	026-01SW101	12 1/2 lb. Intermediate Plate
9	1	022-01PD0042	Seat Pad Upholstery Assembly
10	1	026-01X1313	Seat Assembly
11	1	026-01X0158	Seat Latch Assembly
12	1	026-01X1139	Floating Pulley Mount
13	1	026-1100089	Weight Stack Shield
101	1	026-01X1309	Seat Support
102	1	026-01X1310	Arm Housing
103	1	026-01X1311	Shoulder Upright
104	1	026-01X1305	Cable Guide (Left Arm)
105	1	026-01X1340	Cable Guide (Right Arm)
106	2	026-01X1306	Handle
107	2	026-01X1308	Arm Assembly
108	1	022-01PD0110	Chest Pad Upholstery Assy
109	2	026-01PDR010	Arm Pad Upholstery Assy
116	1	010-01C0265	Weight Stack Cable
117	1	010-01C0266	Fly Wheel Cable

OWNERS MANUAL

HARDWARE LISTING

<u>Key#</u>	<u>Qty.</u>	<u>Part Number</u>	<u>Description</u>
A	2	011-0307061	1/2"-13UNC x 5" Hex Head Bolt (WZ)
B	5	011-0407016	1/2"-13UNC x 3" Hex Head Bolt (WZ)
C	2	011-0407036	1/2"-13UNC x 3 1/4" Hex Head Bolt (WZ)
D	4	011-0407019	1/2"-13UNC x 3 3/4" Hex Head Bolt (WZ)
E	4	011-0407048	12"-13UNC x 1 1/2" Button Head Bolt (WZ)
F	4	011-0101062	5/16"-18UNC x 1 1/4" Hex Head Bolt (WZ)
G	1	011-0311013	Square Head Set Screw
H	1	011-0107010	3/8"-16UNC x 3 1/4" Hex Head Bolt (WZ)
J	1	011-0007043	3/8"-16UNC x 1 3/4" Hex Head Bolt (WZ)
K	2	011-0002042	3/8"-16UNC x 1 1/2" Flat Head Screw
L	4	011-0207030	1/2"-13UNC x 4 1/2" Hex Head Bolt
M	6	011-0101074	1/4"-20UNC x 5" Button Head Bolt
V	2	011-0311012	5/16-18UNC x 5/19" LG Socket Set Screw
AA	40	013-0102003	1/2" Flat Washer
AB	4	013-0302014	1/2" Internal Tooth Lock Washer
AC	4	013-0002001	5/16" Flat Washer
AD	4	013-0102021	5/16" Internal Tooth Lock Washer
AE	4	013-0002004	3/8" Flat Washer
AF	6	013-0002003	1/4" Flat Washer
AG	2	013-0802003	1/2" Thrust Washer
BA	19	012-0304011	1/2" Thin Nylok Nut
BB	2	012-0304008	3/8" Thin Nylok Nut
BC	6	012-0104009	1/4" Nylok Nut
CA	4	026-01PL195	Rubber Foot Pad
CC	2	026-01PL201	Weight Stack Bumper
CD	4	026-01PL133	Stopper
CE	2	026-01M0519	Alum. Bolt on Cap
CF	2	026-01M0749	Square Key Stock
CG	1	026-01M0309	Seat Adjuster Pin
CH	1	026-01M0503	Latch Spring
CJ	1	014-0015001	Seat Adjuster C-Clip
CK	2	026-STD-06-0025	4 1/2" Pulley Wheel
CL	2	026-01M0532	11/16" Flanged Spacer
CM	2	026-STD-05-0454	Aluminum Cap (Flat Head)
CN	2	026-STD-06-0481	Plastic Fender Washer
CP	2	026-01M0199	Quick Release Cable Lock
CQ	1	021-0013135	HS1525 Placard (Right)
CR	1	021-0013134	HS1525 Placard (Left)
CS	6	026-01PL290	.40" Lg. Spacer
CT	2	019-0002014	Rubber Handle Cover (Dia 1.00" x 13" Lg.)
CU	2	026-01PL125	EZ Glide Sleeves
CV	1	016-0101008	1 1/2" x 1 1/2" End Cap
CW	30	026-01SW122	Bushing
CX	4	014-0009007	1" I.D. Flanged Ball Bearing
CY	4	014-0101002	1/2" I.D. Flanged Oilite
CZ	1	026-01PL291	Lanyard Coil
DA	1	026-01M0134	Selector Pin
DB	1	026-01PL291	Lanyard/Selector Pin Stand Off
DC	2	030-0303010	7/16" x 2 3/4" Lg. Roll Pin
DD	1	026-01W111	16 Plate Selector Stem
DE	2	026-01PL134	Guide Rod Bushing
DF	1	026-01PL239	Rubber Thumb Latch
DK	1	016-0101009	2" x 3" Flat End Cap
DM	2	016-0201006	Ø1" Plastic End Cap
DN	4	014-0015014	1/2" C-Clip
DW	4	26-STD-06-0329	Plug

OWNERS MANUAL

5/16" HEX BOLT

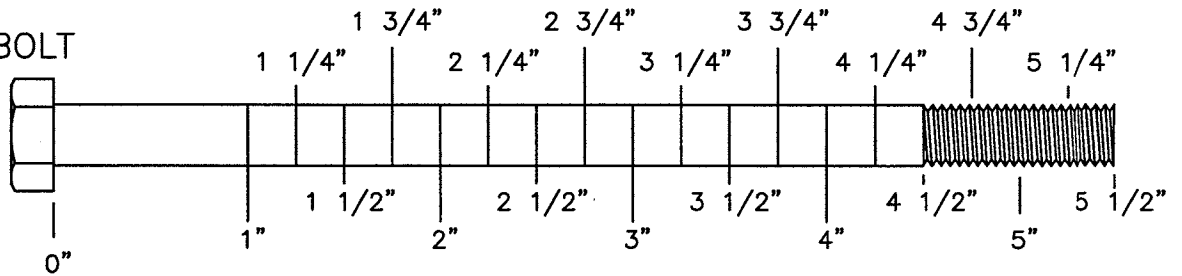
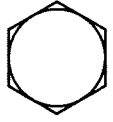

3/8" HEX BOLT

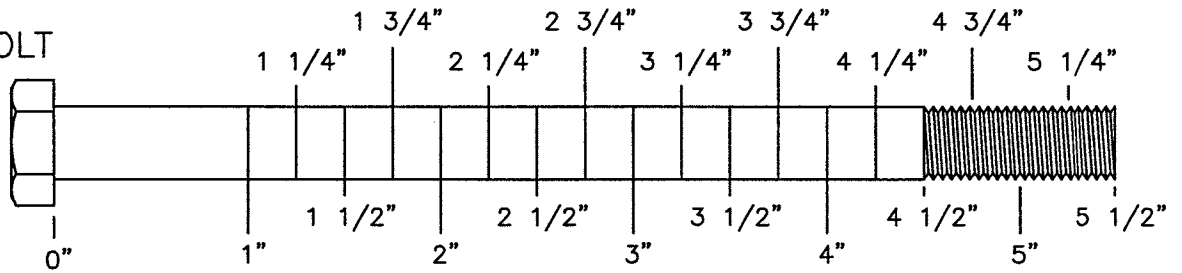
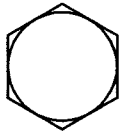

1/2" HEX BOLT

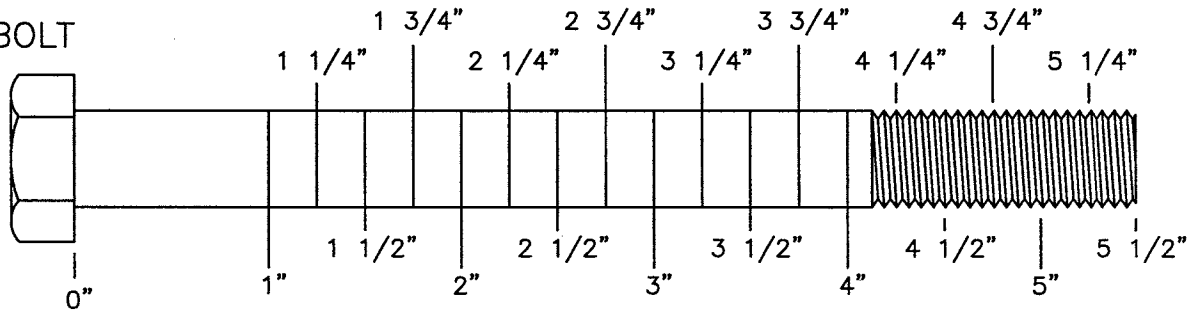
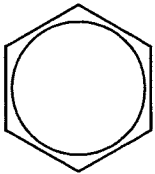

1/2" SHOULDER BOLT

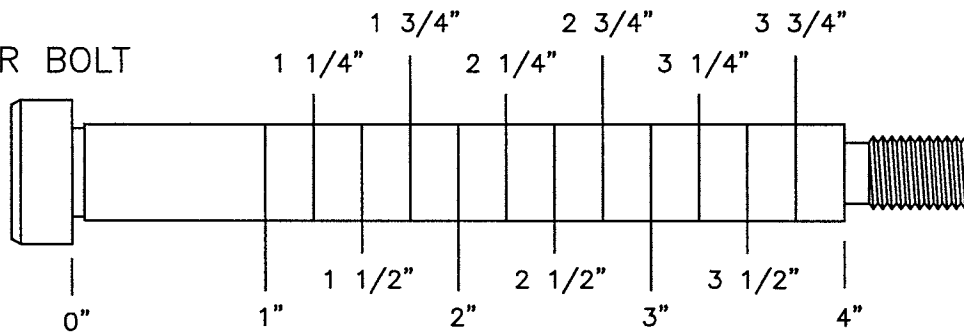
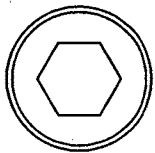

OWNERS MANUAL

3/8" FLATHEAD
SOCKET CAP SCREW

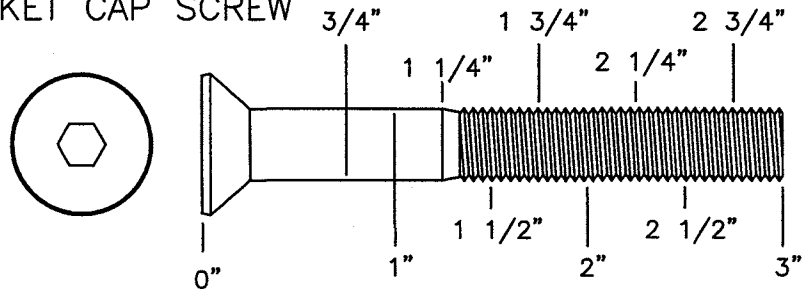

3/8" SOCKET
CAP SCREW

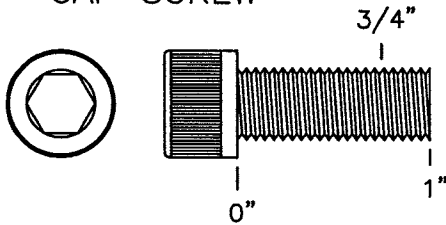

3/8" BUTTON
HEAD CAP SCREW

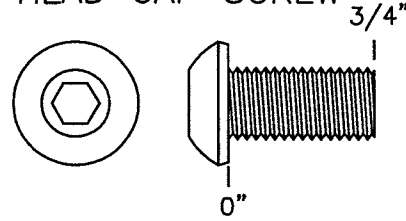

1/4" HEX
BOLT

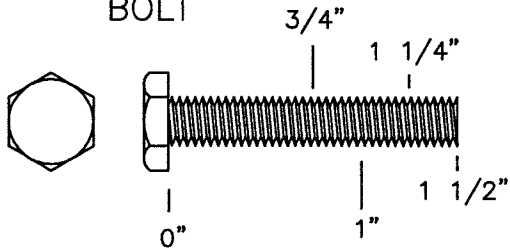

1/2" FLATHEAD
SOCKET CAP SCREW

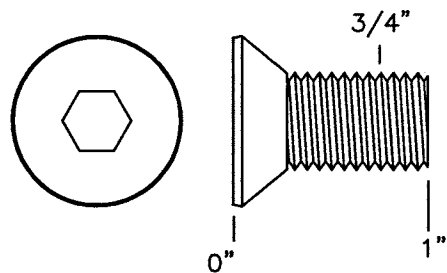

OWNERS MANUAL

5/16"
FLAT WASHER
LARGE, USS, 25mm

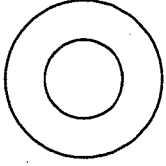

3/8"
FLAT
WASHER

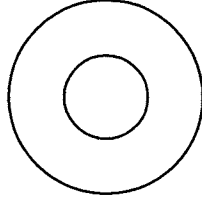

1/2"
FLAT WASHER
SMALL, SAE, 26mm

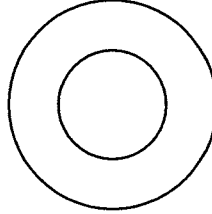

1/2"
FLAT WASHER
LARGE, USS, 34mm

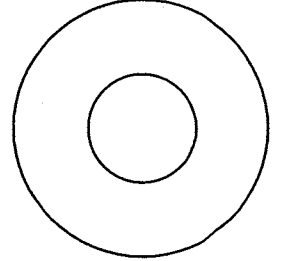

1/4"
LOCK WASHER



3/8"
LOCK WASHER

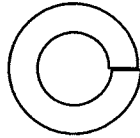

1/2"
LOCK WASHER

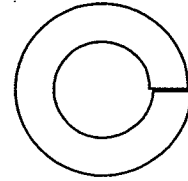

1" SHIM WASHER

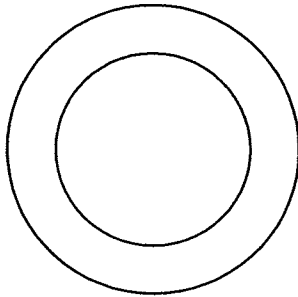

3/8" FENDER WASHER

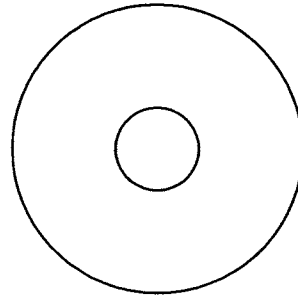

1 1/16"
FENDER WASHER

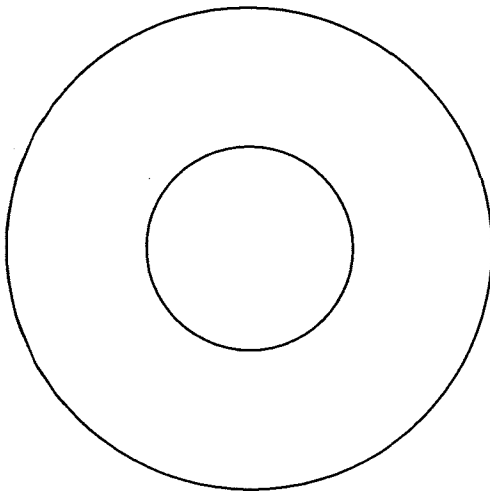

PLASTIC 1 1/16"
FENDER WASHER

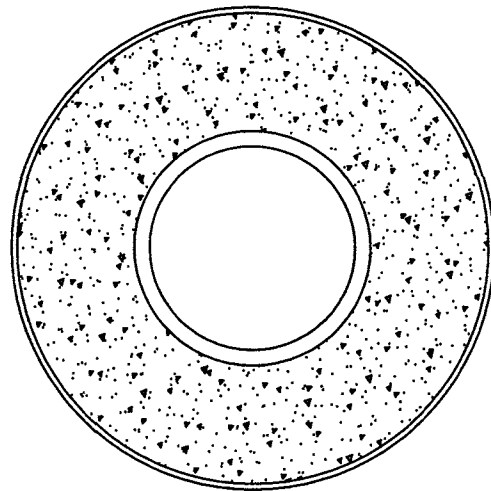

OWNERS MANUAL

1/4" LONG
FLANGED SPACER

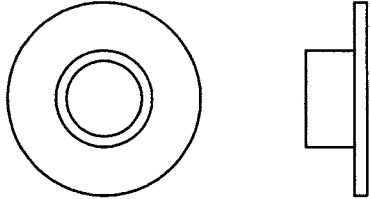

1/2" LONG
FLANGED SPACER

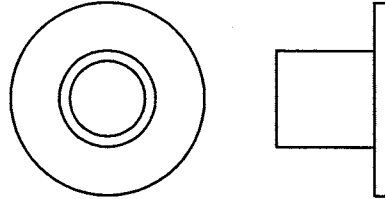

1/4" LONG HEAVY
FLANGED SPACER

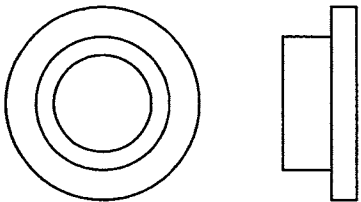

11/16" LONG HEAVY
FLANGED SPACER

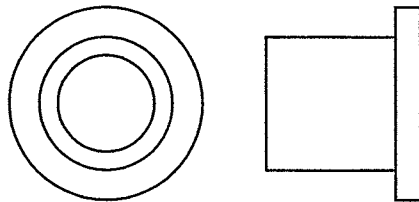

1" LONG HEAVY
FLANGED SPACER

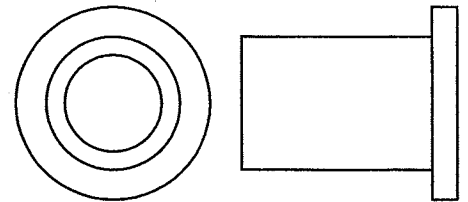

1/2" LONG
SPACER



1" LONG
SPACER

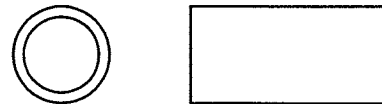

1 3/8" ALUMINUM
FLATHEAD CAP

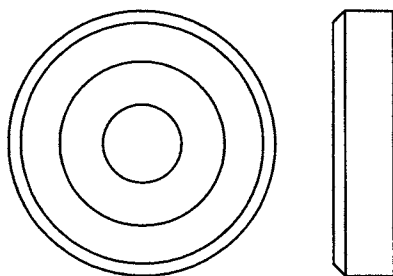

1 5/8" ALUMINUM
FLATHEAD CAP

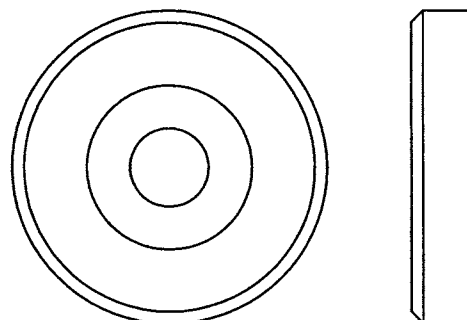

OWNERS MANUAL

WEIGHT CHART

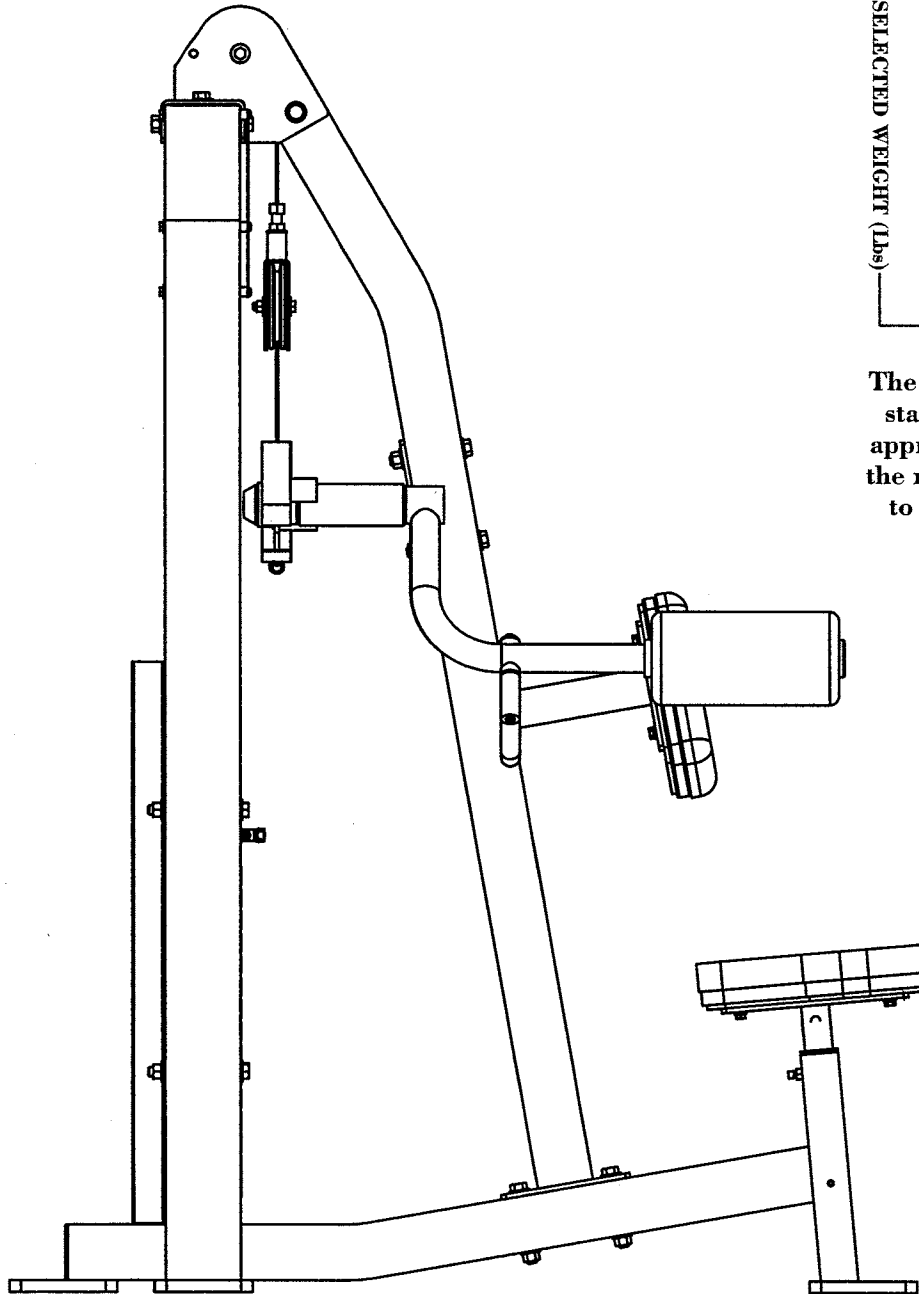

12	(12)	1	20
25	(12 1/2)	2	24
37	(12 1/2)	3	28
50	(12 1/2)	4	32
62	(12 1/2)	5	36
75	(12 1/2)	6	40
87	(12 1/2)	7	44
99	(12 1/2)	8	48
112	(12 1/2)	9	52
125	(12 1/2)	10	56
137	(12 1/2)	11	60
150	(12 1/2)	12	64
162	(12 1/2)	13	68
175	(12 1/2)	14	72
187	(12 1/2)	15	76
200	(12 1/2)	16	80

The chart above shows the standard weight stack for this unit. The weight listed are approximate and have been rounded off to the nearest pound. Hoist reserves the right to modify the weight stack from the one shown without prior notice.

OWNERS MANUAL

OWNERS MANUAL

DECAL PLACEMENTS

Decal Descriptions

- 1 - 021-0004064
- 2 - 021-0003136
- 3 - 021-0003130
- 4 - 021-0003131
- 5 - 021-0004029
- 6 - 021-0004026
- 7 - 021-0003011
- 8 - 021-0003138
- 9 - 021-0004061

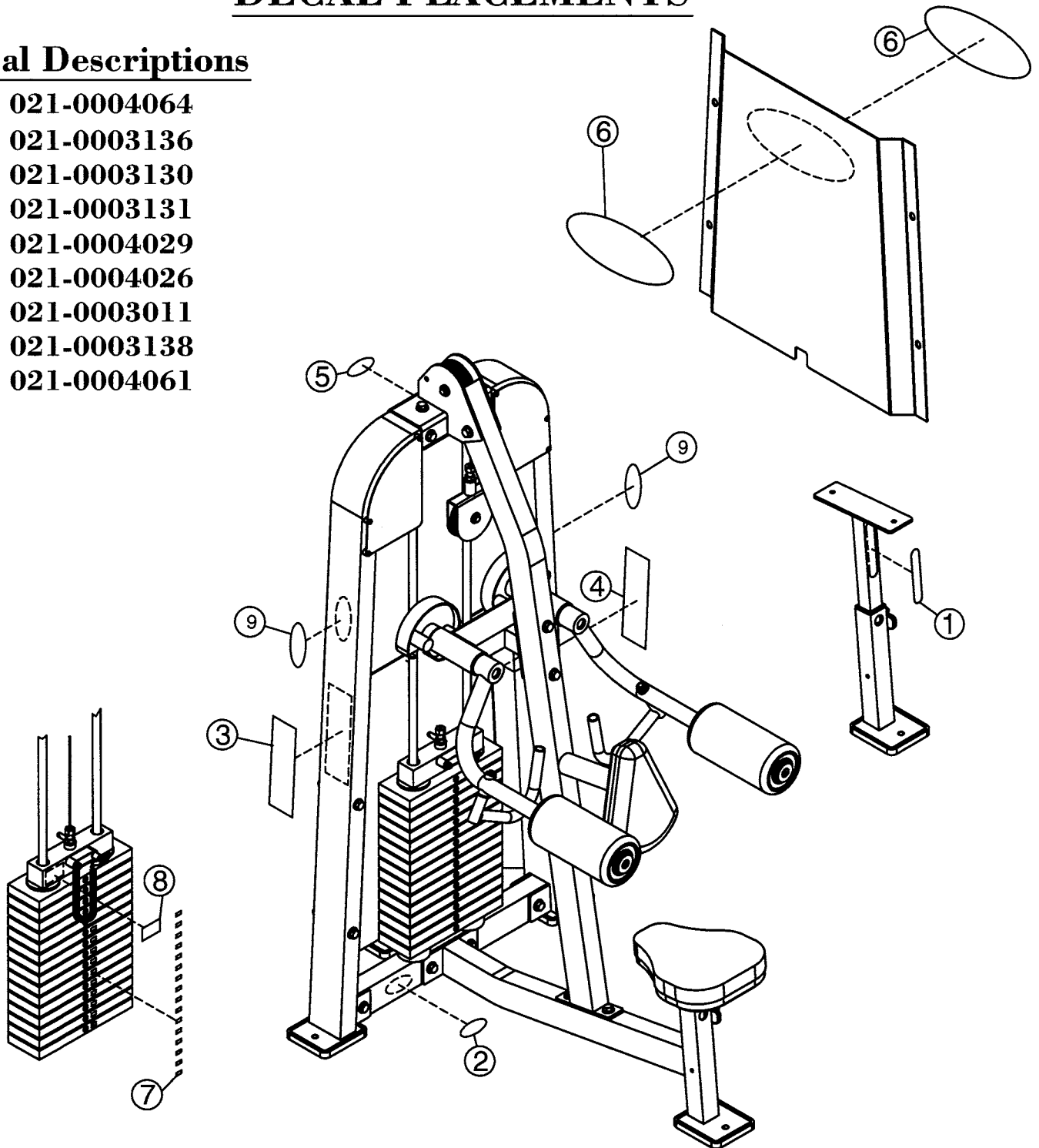

OWNERS MANUAL

DECAL PLACEMENTS

This decal has been attached to this piece of equipment to provide information regarding operation, safety and maintenance. Before use, take the time to read these decals.



021-0003136



021-0004029



021-0004061

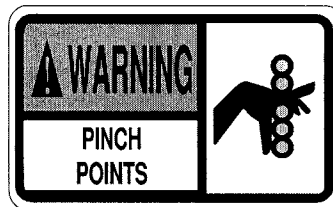

021-0003138

OWNERS MANUAL

DECAL PLACEMENT

This decal has been attached to this piece of equipment to provide information regarding operation, safety and maintenance. Before use, take the time to read these decals.

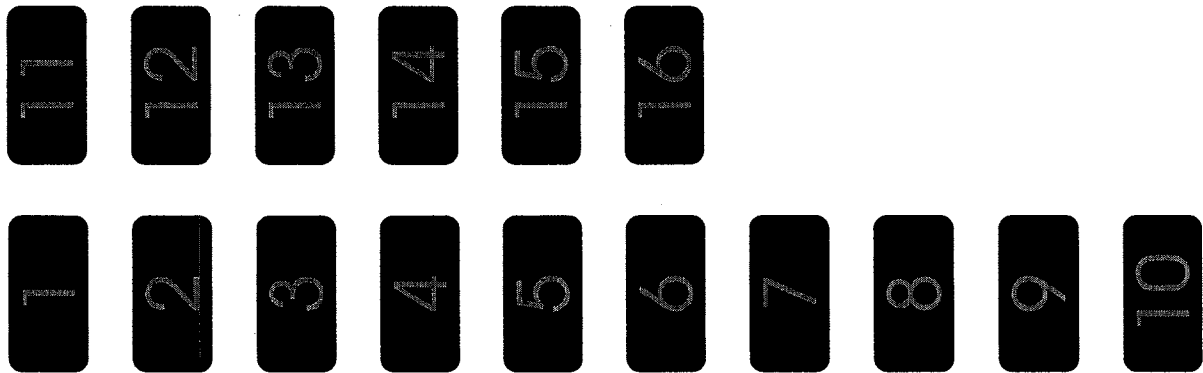

021-0003011

1 2 3 4 5 6

021-0004064

OWNERS MANUAL

DECAL PLACEMENT

This decal has been attached to this piece of equipment to provide information regarding operation, safety and maintenance. Before use, take the time to read these decals.

WARNING

USE ONLY GENUINE HOIST REPLACEMENT PARTS. FAILURE TO DO SO WILL VOID WARRANTY AND COULD RESULT IN PERSONAL INJURY OR EVEN DEATH. THERE IS A RISK ASSUMED BY INDIVIDUALS WHO USE THIS TYPE OF EQUIPMENT. TO MINIMIZE THE RISK ALWAYS FOLLOW THESE SIMPLE RULES.

1. READ & UNDERSTAND ALL ENCLOSED INSTRUCTIONS before using this equipment.
2. INSPECT EQUIPMENT BEFORE EACH USE. Replace all parts at the first signs of wear or damage. If in doubt about a certain part, DO NOT use the equipment until the part is replaced. Failure to replace worn or damaged parts may result in injury.
3. FOLLOW ROUTINE MAINTENANCE SCHEDULE.
4. CONSULT YOUR PHYSICIAN BEFORE STARTING ANY EXERCISE PROGRAM. Warm up properly before engaging in weight resistance training. Stop exercising if you feel faint or dizzy.
5. TO PREVENT THE POSSIBILITY OF SERIOUS INJURY, KEEP CLEAR OF ALL MOVING PARTS. Do not attempt to free any jammed part by yourself. Obtain assistance in order to avoid possible injury.
6. Take your time and do not rush the exercise. Practice proper breathing. NEVER hold your breath.
7. CHILDREN SHOULD NOT BE ALLOWED TO USE THIS EQUIPMENT. To avoid possible injury, children should be kept at a safe distance when this equipment is in use. Teenagers should not use this equipment without adult supervision.
8. CALL YOUR AUTHORIZED HOIST DISTRIBUTOR if you have any questions on the proper use or maintenance of this equipment.

021-0003130

NOTICE

<i>COMMERCIAL MAINTENANCE</i>	Daily	Weekly	Monthly	Months ⁶	Yearly
Inspect; Links, Pull Pins, Snap Locks, Swivels, Weight Stack Pins	X				
Clean; Upholstery	X				
Inspect; Cables or Belts and their tension	X				
Inspect; Accessory Bars and Handles		X			
Inspect; All Decals		X			
Inspect; All Nuts and Bolts, Tighten if Needed		X			
Inspect; Anti-Skid Surfaces		X			
Clean & Lubricate; Guide Rods with a Teflon (PTFE) based lubricant (Superlube)			X		
Lubricate; Seat Sleeves, Turcite Bushings, Linear Bearings			X		
Clean and Wax; All Glossy Finishes				X	
Repack with Grease; Linear Bearings				X	
Replace; Cables, Belts and Connecting Parts					X

021-0003131

HS1525 Assembly



Page - 36

**OWNERS
MANUAL**

DECAL PLACEMENT

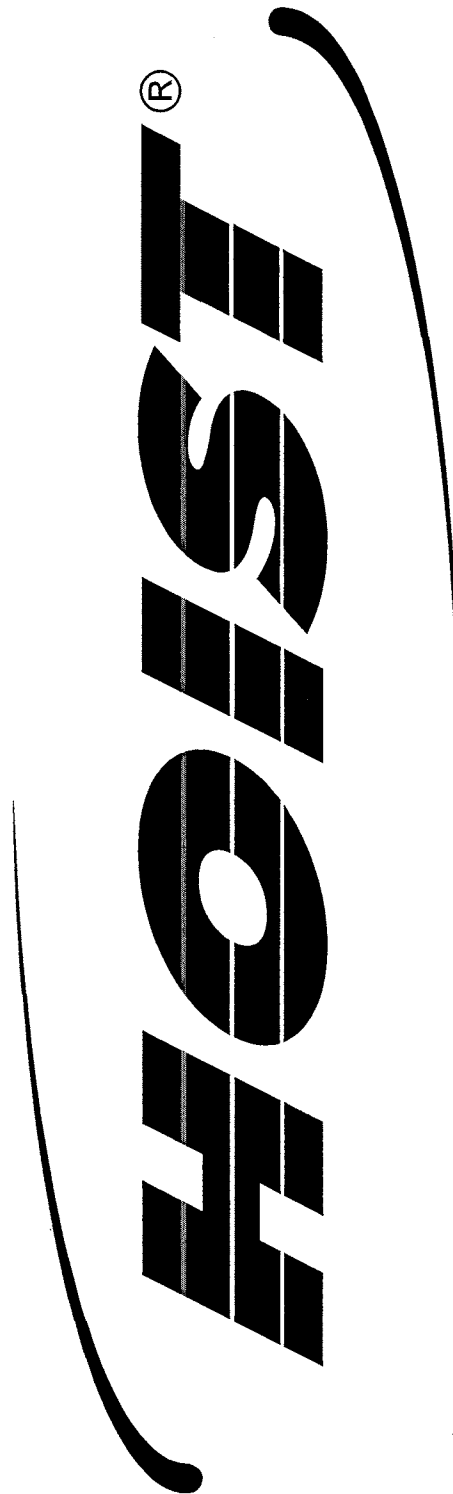

021-0004026

OWNERS MANUAL

OWNERS MANUAL

WEIGHT TRAINING TIPS

Always consult your physician before starting any exercise program.

Hoist equipment is designed to maximize your time spent working out. Having an exercise routine planned out in advance will allow you to get the most benefit out of the time spent exercising, and will also enable you to work all the major muscle groups.

Warm up properly before engaging in weight resistance training. Stretching, yoga, jogging, calisthenics or other cardiovascular exercise can help prepare your body for the heavier workload of lifting weights.

Learn how to perform the exercise correctly before using heavy weight. Correct form is important to avoid injury and to ensure that you work the proper muscle groups.

Know your limitations. If you are new to weight training or are embarking on an exercise regimen after a long layoff, start slowly and build foundational strength over a longer period of time.

Pay attention to your breathing. Exhale when you exert is a general rule of thumb. Never hold your breath.

OWNERS MANUAL

MAINTENANCE SCHEDULE

ROUTINE	COMMERCIAL MAINTENANCE	HOME MAINTENANCE	LATEST DATE ENTRY															
Inspect; Links, Pull Pins, Snap Locks, Swivels, Weight Stack Pins	DAILY	WEEKLY																
Clean; Upholstery	DAILY	WEEKLY																
Inspect; Cables or Belts and their tension	DAILY	WEEKLY																
Inspect; Accessory Bars, and Handles	WEEKLY	3 MONTHS																
Inspect; All Decals	WEEKLY	3 MONTHS																
Inspect; All Nuts and Bolts, Tighten if needed	WEEKLY	3 MONTHS																
Inspect; Anti-Skid Surface	WEEKLY	3 MONTHS																
Clean & Lubricate; Guide Rods with a Teflon (PTFE) based lubricant (Superlube)	MONTHLY	3 MONTHS																
Lubricate; Seat Sleeves, Turcite Bushings, Linear Bearing	MONTHLY	3 MONTHS																
Clean and Wax; All Glossy Finishes	6 MONTHS	YEARLY																
Repack with Grease; Linear Bearings	6 MONTHS	YEARLY																
Replace; Cables, Belts and Connecting Parts	YEARLY	3 YEARS																

*Your equipment comes with a commercial maintenance decal.
For personal, in home use, please follow the home maintenance schedule listed above.*

OWNERS MANUAL

HOIST FITNESS SYSTEMS GENERAL MAINTENANCE INFORMATION

Links, Pull-Pins, Snap Locks, Swivels, Weight Stack Pins:

- *Check all pieces for signs of visible wear or damage.*
- *Check springs in snap hooks and pull-pins for proper tension and alignment.*
- *If the spring sticks or has lost its rigidity, replace it immediately.*

Upholstery:

- *To ensure prolonged upholstery life and proper hygiene, all upholstered pads should be wiped down with a damp cloth after every workout.*
- *Periodically take the time to use a mild soap or an approved vinyl upholstery cleaner to deter the onset of cracking or drying. Avoid using any abrasive cleaners or cleaners not intended for use on vinyl.*
- *Replace ripped or worn upholstery immediately.*
- *Keep sharp or pointed objects clear of all upholstery.*

Guide Rods:

- *Wipe clean with a dust free rag. Lubricate once a week with a Silicon or Teflon based lubricant.*

Decals:

- *Inspect and familiarize yourself with any safety warnings or other user information posted on each decal.*

Nuts and Bolts:

- *Inspect all nuts and bolts for any loosening and tighten if needed.*
- *Go through a re-tightening sequence periodically to ensure that all hardware is tensioned properly.*

Anti-Skid Surfaces:

- *These surfaces are designed to supply secure footing and need to be replaced if they appear worn or become slippery.*

Belts and Cables:

- *Hoist uses only high quality belt, and mil-spec cables.*
- *Visually inspect the belts and cables for fraying, cracking, peeling or discoloration.*
- *While the machine is not in use, carefully run your fingers along the belt or cable to feel for thinning or bulging areas.*
- *Replace belts and cables immediately at the first signs of damage or wear. Do not use equipment until belts or cables have been replaced.*

OWNERS MANUAL

GENERAL MAINTENANCE INFORMATION (CONTINUED)

Belt and Cable Tension:

**Referring to the Owners Manual, when belts or cables are used check all bolt attachments to be sure they are properly attached.*

**Check slack in cables and re-adjust cable tension if needed.*

Seat Sleeves, Turcite Bushings:

**Wipe down adjusting tubes with a dust free rag before applying lubricant.*

**Lubricate seat sleeves and turcite bushings with a Silicon or Teflon based lubricant spray.*

Linear Bearings:

**Referring to the Owners Manual carefully dis-assemble the bearing from its housing and place a finger full of light grease (lithium, super lube, etc.) into the inside of the bearing. Using your finger, press the grease into the ball-bearings and their tracks. repeat until the ball-bearing tracks are full of grease. Insert the shaft back into the bearing and wipe off excess grease.*

PLEASE KEEP THIS FOR YOUR RECORDS

OWNERS MANUAL

HOIST FITNESS SYSTEMS LIMITED LIFETIME WARRANTY

Hoist Fitness Systems warrants this product to the **original purchaser** to be free from defects in workmanship and/or materials under normal use or service. If at any time a component part is defective, Hoist Fitness Systems shall repair or replace it (at Hoist Fitness Systems option) within a reasonable period of time. This warranty does not cover costs of removal, transportation or reinstallation. This warranty shall not apply if the defect was caused by misuse, neglect or normal wear and tear.

Starting from the original date of purchase, normal wear and tear shall be considered as the following:

COMMERCIAL USE: All malfunctions of upholstery, grips, paint, and chrome that occur after 180 days; all malfunctions of electronic components, belts, or **cables** after one year; all malfunctions of pulleys, bearings, or bushings that occur after five years. The frame and all welded components are warranted for the life of the product.

HOME USE: All malfunctions of grips, paint, and chrome that occur after one year; all malfunctions of electronic components, belts, **cables**, or upholstery that occur after three years; all malfunctions of pulleys, bearings, or bushings that occur after five years. The frame and all welded components are warranted for the life of the product.

Hoist Fitness Systems sole responsibility shall be to repair or replace the component within the terms stated above. Hoist Fitness Systems shall not be liable for any loss or damage of any kind including any incidental or consequential damages resulting, directly or indirectly from any warranty expressed or implied or any other failure of this product.

WHAT IS NOT COVERED BY THIS WARRANTY

Hoist's sole obligation under this warranty is limited to either repair or replacement of parts, subject to the additions below. This warranty neither assumes nor authorizes any person to assume obligations other than expressly covered by this warranty.

NO CONSEQUENTIAL DAMAGES. Hoist is not responsible for economic loss; profit loss; or special, indirect, or consequential damages.

WARRANTY IS NOT TRANSFERABLE. This warranty is not assignable and applies only in favor of the original purchaser/user to whom delivered. Any such assignment or transfer shall void the warranties herein made and shall void all warranties, expressed, implied or statutory, except the one (1) and five (5) year warranties described above. These warranties are exclusive and in lieu of all other warranties, including implied warranty and merchantability or fitness for a particular purpose. There are no warranties which extend beyond the description on the face hereof.

ALTERATION, NEGLIGENCE, ABUSE, MISUSE, NORMAL WEAR & TEAR, ACCIDENT, DAMAGE DURING TRANSIT OR INSTALLATION FIRE, FLOOD, ACTS OF GOD. Hoist is not responsible for the repair or replacement of any parts that Hoist determines have been subjected after the date of manufacture to alteration, neglect, abuse, misuse, normal wear & tear, accident, damage during transit or installation, fire, flood, or an **ACT OF GOD**.

TRANSPORTATION COSTS. Hoist will accept parts covered under this warranty freight collect, provided that shipment has received prior approval. Hoist is not responsible for any other transportation costs, but will ship freight collect parts either repaired or replaced under these warranties.

WARRANTY CLAIMS. All claims should include: model number, the serial number, proof of purchase, date of installation, and all pertinent information supporting the existence of the alleged defect.

Hoist Fitness Systems
9990 Empire St. #130
San Diego, Calif. 92126
(800)548-5438
Web Site - www.hoistfitness.com

PLEASE KEEP THIS FOR YOUR RECORDS